

M8324 M8486

32.0 - 48.0 tonne mobile column lifts

The very reliable screw drive with lift and safety nut is a long lasting and easy to maintain system

In the column base, spring mounted castors allow easy movement of the columns and secure positioning when lifting

The power, control and operation module is mounted in a remote, mobile stand, allowing operation of the columns at any point within the cable length

Various control possibilities allows single column control, single axle control or all column control



BRADBURY

EQUIPMENT

M8324 & M8486

32.0 - 48.0 tonne mobile column lifts

Technical data

Number of columns 4 / 6
Capacity per column (CE) 8.0 tonne
Max height reached 1.700 mm
Possible wheel sizes Tyre sizes 870 – 1080 mm
18 – 24 mm / inch
Lift up lift down time 140 / 130 seconds
Motor power per column 4 / 6 2,2 / 3 kW
Power requirements 400 V/3 Ph/50 Hz
Power feed per column 5 x 2,5 / 25 mm²
Column dimensions 1070(W) x 1000(L) x 2530(H) mm
Weight/column 550 kg

Standard accessories

Wheel dolly

Optional accessories

Small Wheel Adaptors.
Trailer Beam.

Application

Bus and coach workshops
Logistic workshops
HGV workshops
General repair bay (Small wheel adaptors may be required)

Bradbury M8324 and M8486 8.0 tonne

Set of four or six mobile column lifts complete with one mobile control box. Each column lifts 8.0 tonne capacity and is suitable for lifting Commercial Vehicles, buses, Light Commercial Vehicles, 4 x 4's and Cars (Wheel Reducers may be required). Can be extended up to 8 columns.

Description

Lift column head drive motor with rolled steel drive screw and bronze lift nut, superbly engineered safety cut off system. Automated drive disengagement when the lift is at its maximum height. Mobile power and control unit. Includes electronically controlled symmetrical lifting of the columns. Controller for selective lifting of either all four columns or two columns per axle, or single columns. All power functions in one box. Main power cable with plug is pre-connected to the power box. Length 10 meters. Four individual power cable for the columns, Length 15 meters.

Column mover

Stabilising screws can be engaged for uneven floors. With ball head and/or hydraulic lifting action, gives the column the required manoeuvrability around all even surfaces.

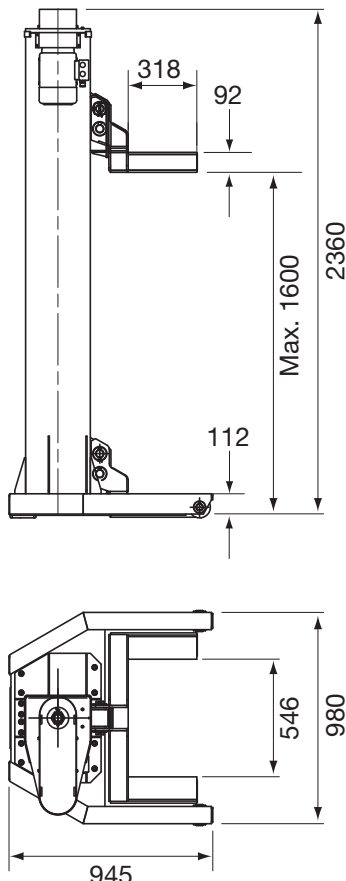

Column mover



Control box for 4 column system

Other products in Bradbury's quality range

Two post lifts
Four post lifts
Scissor lifts
Commercial vehicle lifts (Fixed and mobile)
VOSA approved MOT & ATL equipment
Car and commercial vehicles roller brake testers
Jacking beams
Headlamp aligners
Wheel and tyre equipment (Motorcycle, car & commercial)

Bradbury Equipment

153-165 Bridge Street Northampton NN1 1QG
T +44(0) 1604 828 648
F +44(0) 1604 609 684
E sales@bradburyequipment.co.uk

Registered office 153-165 Bridge Street Northampton NN1 1QG
Registered in England 4666699



FS 23808