

# H8101

## 2.5 tonne mobile electro-hydraulic scissor lift

Mid raise scissors lift for tyre & car body shops

Very strong steel works

Mechanical safety device

Extremely silent power pack

Non return valve provides safety against hydraulic failure

Acoustic signal during lifting/descent

Pins with self-lubricating bushings

Full access to sides, front and rear of the vehicle

Traveling power pack



**BRADBURY**



**EQUIPMENT**

# H8101

## 5.0 tonne mobile electro-hydraulic scissor lift

### Technical data

Capacity	2500 kg
Weight	480 kg
Lift/Lower	12/35 seconds
Lifting height	930 mm
Length	1400/1932 mm
Overall width	1770 mm
Motor	3 kw - 400V/50 Hz
Concrete	35N/mm <sup>2</sup> strength 160 mm minimum thickness Withstand 2.25 tonne static load Withstand 4.5 tonne shock load Continuous slab without cracks or joints

### Application

Car service bays  
Bodyshops in conjunction with Jig and panel repairs  
Brake repairs and service  
Suspension replacement  
Transmission repair and replacement  
General repair bay



### Details

Minimal height 95mm, easy to drive-over even with low cars.

### Optional accessories

Set of wheels  
Auxiliary drive on/ drive off ramps

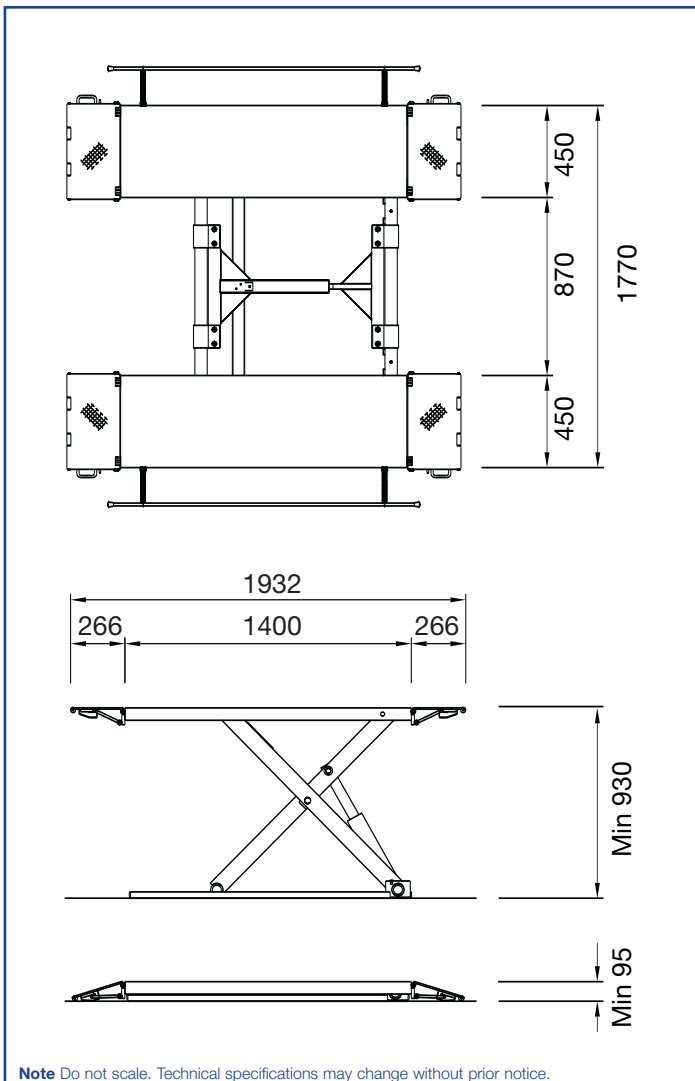

### Other products in Bradbury's quality range

Two post lifts  
Four post lifts  
Scissor lifts  
Commercial vehicle lifts  
VI approved MOT equipment  
Roller brake testers for both car and commercial vehicles  
Jacking beams

### Bradbury Equipment

153-165 Bridge Street Northampton NN1 1QG

T +44(0) 1604 828 648

F +44(0) 1604 609 684

E sales@bradburyequipment.co.uk

Registered office 153-165 Bridge Street Northampton NN1 1QG

Registered in England 4666699



Note Do not scale. Technical specifications may change without prior notice.