

DUNLOP DL45 MK4

2 Post Electro-Hydraulic 4.0 Tonne Lift



Features

- Electrically operated safety ratchets
- Control box operates all functions
- Assymmetric arm configuration
- 3 stage front arms
- Choice of 3 phase or single phase
- Automatic arm locks
- Low friction sliding carriage guides
- Adjustable top limit switch allows use in low ceiling buildings
- Two sets of lift pad extensions: 100 mm and 150 mm fitting together to form 250mm
- Screw adjustable lifting pads
- 12 months warranty parts and labour
- CE approved

Technical data

Operation	Electro-hydraulic
Capacity	4000 kg
Lifting time	50 seconds
Lowering time	30 seconds
Lifting height	1850 mm
Lowest height	130-235 mm
Motor 3 phase	2 hp x 380 volt x 50 Hz
Motor single phase	2.5 hp x 230 volt x 50 Hz
Width external	3456 mm

Application

- Car and light commercial workshop
- Brake repairs and service
- Suspension replacement
- Transmission repair and replacement
- Tyre shop
- General repair bay

Elevation & plan

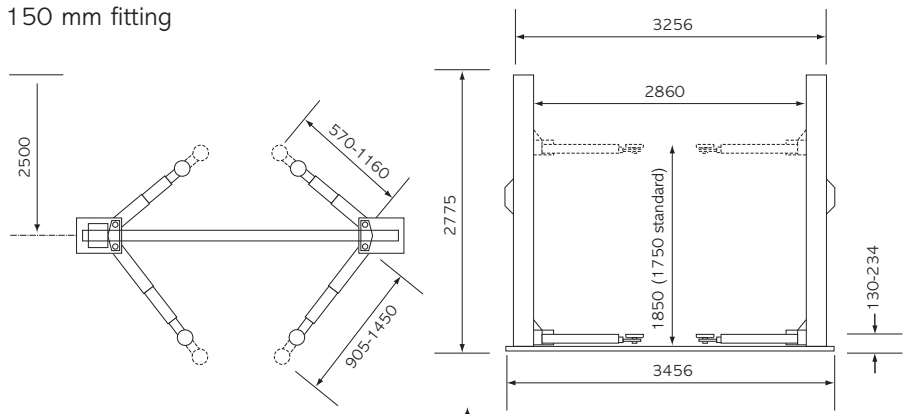

Elevation & plan for reference purposes only, do not scale

Distributed by

DL45 - 16:03:09